

iSSi Spindle and Bearing Tech

iSSi pedals are constructed in three different bearing and spindle configurations to ensure that any rider, from beginner to expert, will find one of our pedals suitable for his or her riding needs.

DOUBLE BUSHING

For the recreational rider who wants to make their first move from flat pedals to clipless, iSSi models constructed with double bushings provide an economical solution. Bushings offer plenty of performance without the added machining cost required for cartridge bearings.

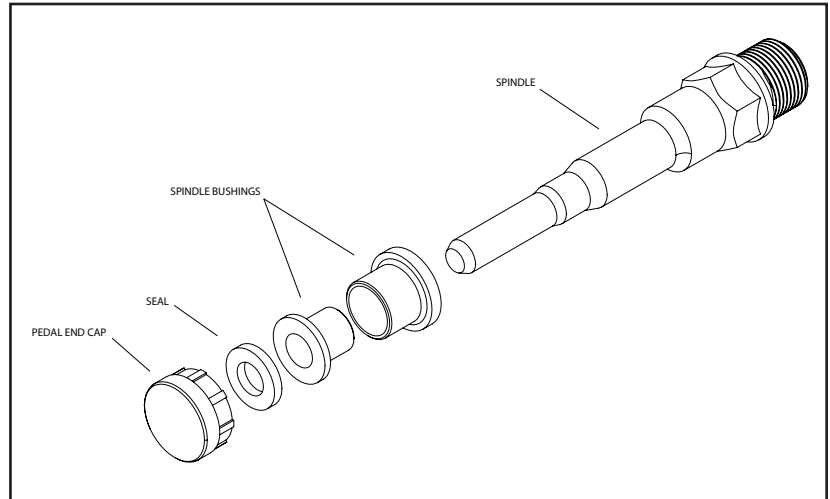

BEARING/BUSHING

iSSi's bushing and bearing spindle offers a noticeable jump in smoothness and durability. The addition of an outboard sealed cartridge bearing provides better pedal body to spindle alignment and longer bearing life.

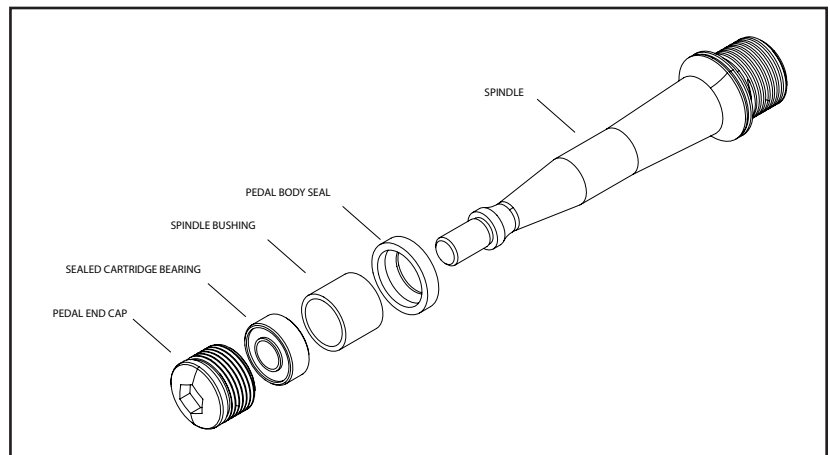

TRIPLE BEARING

iSSi's triple bearing models offer the smoothest rotation possible and the best feeling interface between pedal and rider. The combination of precision spindle machining and high quality cartridge bearings grants years of high performance and minimal maintenance.

